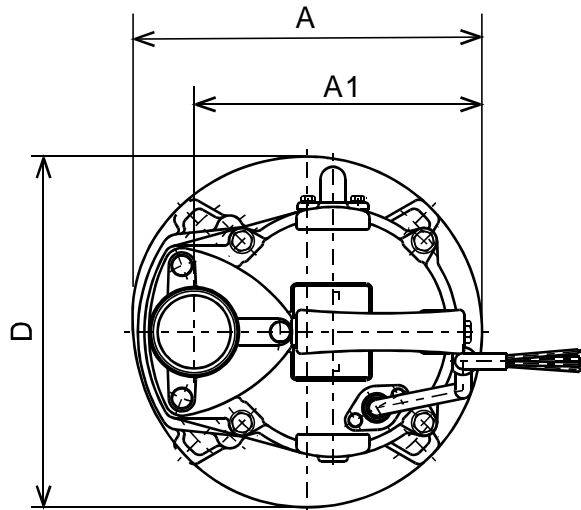
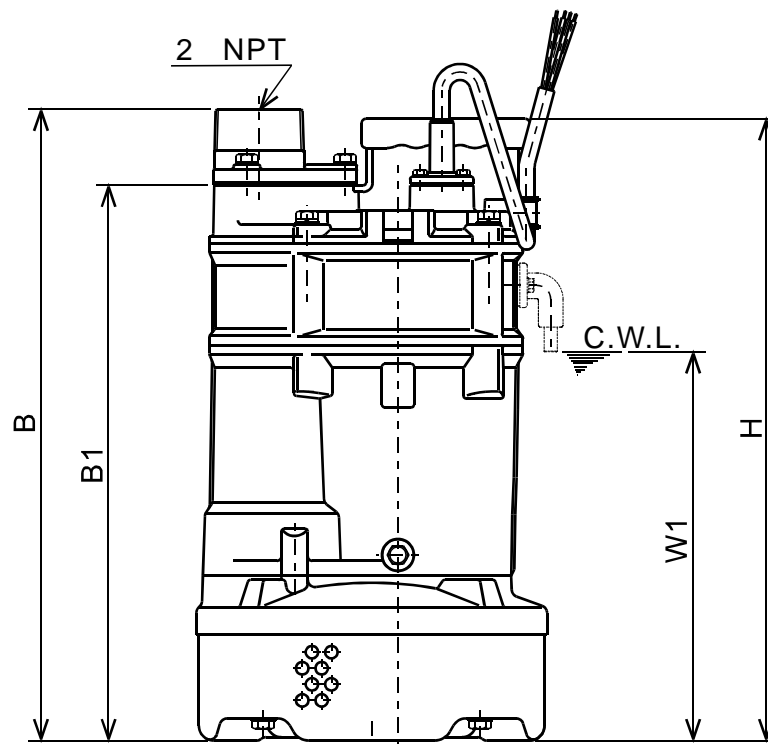

**TSURUMI PUMP**
**KTVE - SERIES**  
**SEMI-VORTEX - DEWATERING PUMPS (AUTO TYPE)**
**DIMENSIONS**
**KTVE21.5-61**  
**KTVE22.2-61**

C.W.L. : Continuous running WaterLevel

**DIMENSIONS:USCS (Inch)**

Model	HP	NOM. SIZE	Pump & Motor						C.W.L.	Wt. (lbs.)
			A	A1	B	B1	D	H	W1	
KTVE21.5-61	2	2"	9 7/16	7 3/4	17	14 15/16	9 7/16	16 3/4	10 1/2	48
KTVE22.2-61	3	2"	9 7/16	7 3/4	17	14 15/16	9 7/16	16 3/4	10 1/2	55

**DIMENSIONS:METRIC (mm)**

Model	kW	NOM. SIZE	Pump & Motor						C.W.L.	Wt. (kg)
			A	A1	B	B1	D	H	W1	
KTVE21.5-61	1.5	50	240	197	432	380	240	425.5	266	22.0
KTVE22.2-61	2.2	50	240	197	432	380	240	425.5	266	25.0



# KTVE - SERIES

## SEMI-VORTEX - DEWATERING PUMPS (AUTO TYPE)

# PERFORMANCE CURVE

MODEL	BORE	HP	KW	RPM	SOLIDS DIA	LIQUID	SG.	VISCOSITY	TEMP.
KTVE21.5-61	2"/50mm	2	1.5	3440	0.334"/8.5mm	Water	1.0	1.123 cSt.	60°F
PUMP TYPE	PHASE	VOLTAGE	AMPERAGE	HZ	STARTING METHOD	INS. CLASS			
Semi-Vortex - Dewatering Pump	3	208 / 230 / 460 / 575	6.0 / 5.4 / 2.7 / 2.1	60	Direct On Line	E			
CURVE No.	DATE	PHASE	VOLTAGE	AMPERAGE	HZ	STARTING METHOD	INS. CLASS		
-	-	-	-	-	-	-	-		

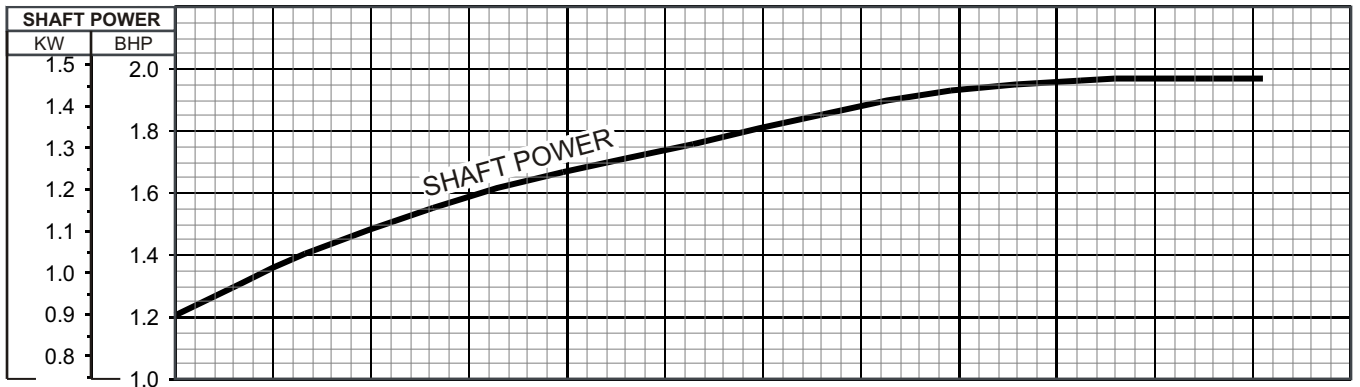
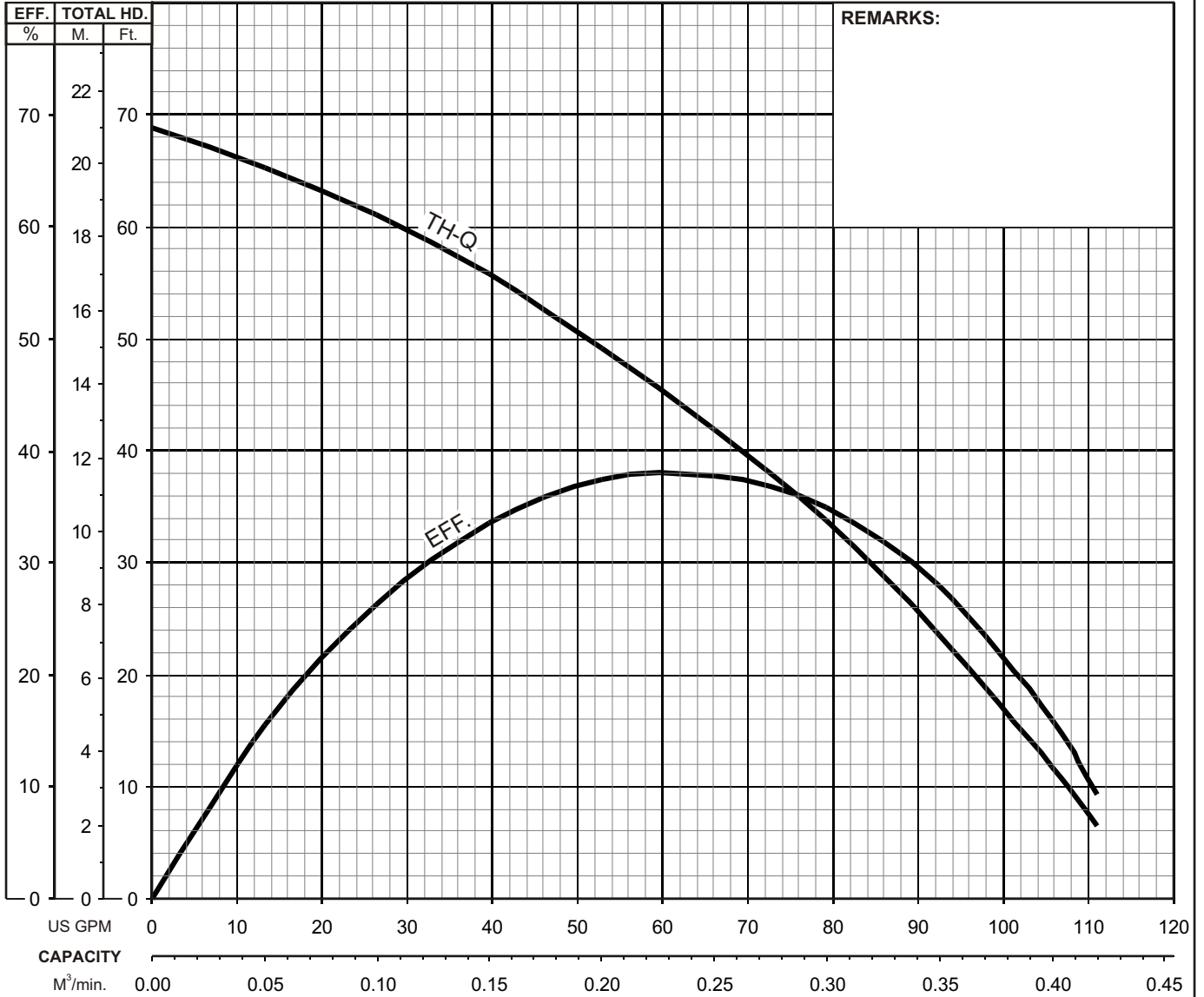

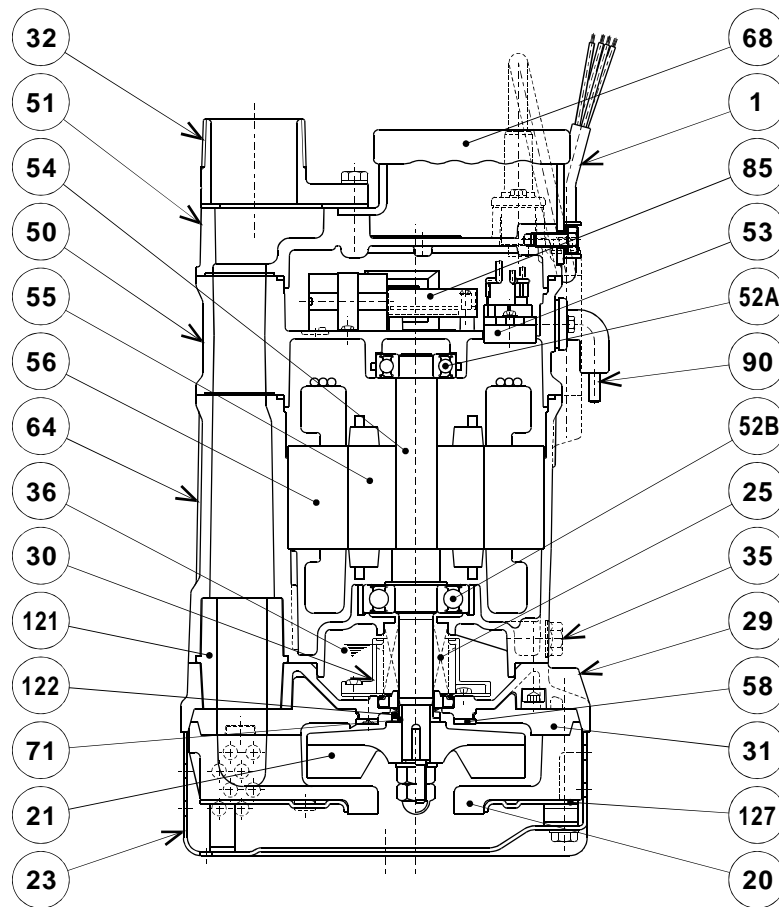
**TSURUMI PUMP**
**KTVE - SERIES**  
**SEMI-VORTEX - DEWATERING PUMPS (AUTO TYPE)**
**SECTIONAL VIEW**
**KTVE21.5-61**  
**KTVE22.2-61**

ITEM#	DESCRIPTION	MAIN MATERIAL / NOTE	ASTM, AISI CODE	RELATED EN CODE	Q'TY
1	Power Cable	PVC Sheath AWG16/4-50ft			1
20	Pump Casing	Butadiene Rubber + Natural Rubber			1
21	Impeller	Ductile Cast Iron	A536 100-70-03	EN 1563 GJS-700-2	1
23	Suction Strainer	Steel (Cold Rolled)	A109/A1008	EN 10130	1
25	Mechanical Seal	Silicon Carbide / H-20T			1
29	Oil Casing	Aluminum Alloy Die Casting	B85 A383,0	EN1706 AC-46100	1
30	Oil Lifter	PBT Resin			1
31	Wear Ring	Butadiene Rubber + Natural Rubber			1
32	Discharge Connection	Cast Iron / NPT 2"	A48M Class30B	EN 1561 GJL-200	1
35	Oil Plug	Stainless Steel	S 30400	1.4301	1
36	Lubricant	Turbine Oil ISO VG32 or SAE10W-20			
50	Motor Bracket	Aluminum Alloy Die Casting	B85 A383,0	EN1706 AC-46100	1
51	Motor Head Cover	Aluminum Alloy Die Casting	B85 A383,0	EN1706 AC-46100	1
52A	Upper Bearing	#6204ZZC3			1
52B	Lower Bearing	#6305ZZC3			1
53	Motor Protector				1
54	Shaft	Stainless Steel	S 40300	1.4000	1
55	Rotor				1
56	Stator				1
64	Motor Housing	Aluminum Alloy Die Casting	B85 A383,0	EN1706 AC-46100	1
68	Handle	Steel (Cold Rolled) + Nitrile Butadiene Rubber	A109/A1008	EN 10130	1
71	Shaft Sleeve	Stainless Steel	S 30400	1.4301	1
85	Relay Unit				1
90	Level Sensor (Electrode)	Stainless Steel + Chloroprene Rubber	S 30400	1.4301	1
121	Duct Sleeve	Styrene Butadiene Rubber			1
122	V-Ring	Nitrile Butadiene Rubber			1
127	Fixing Plate	Steel (Cold Rolled)	A109/A1008	EN 10130	1

PARTS LIST		LIGHTWEIGHT AUTOMATIC DEWATERING PUMP				2/13/2018
ITEM	PART No.	DESCRIPTION	QTY	SIZE	MATERIAL	NOTES
1	140-427-17	Hex.Bolt (w/Plain Washer)	2	M5x15	SUS304	
2	001-803-33	Cabtyre Cable Set (50') 60Hz(USA)	1	VCT4Cx1.25mm2	LBT	
3	003-190-10	Gland	1		SUS316	
4	068-273-19	Handle	1	KTVE21.5/22.2-51/61	SPC+NBR	
5	010-126-17	Cable Clip Rubber	1	HS2	NBR	
6	140-054-19	Hex.Bolt	1	M8x20	SUS304	
7	010-130-14	Cable Clip	1	HK2-4/15	SPC	
8	140-506-11	Hex.Bolt (w/Plain Washer)	3	M8x35	SUS304	
9	142-210-11	Plain Washer	3	d8.6xd13.4x1t	SUS304	
10	032-351-11	Hose Coupling	1	KTV2-15(NPT-2)	FC	
11	121-001-09	Packing	1	KTV2-15/22	NBR	*
12	140-070-11	Hex.Bolt	4	M8x100	SUS304	
13	142-163-18	Spring Washer	4	M8	SUS304	
14	142-127-10	Plain Washer	4	M8	SUS304	
15	051-254-12	Motor Head Cover	1		ADC	
16	143-085-34	Pan Screw (w/Spring Washer)	1	M4x6	C3604	
17	114-000-89	Relay Unit	1Set	ME0K1-KA3		interchangable with OLD part# 114-000-65
	143-183-17	Truss Screw	4	M3x20	SUS304	
18	143-136-15	Truss Screw	2	M4x10	SWRM	
19	053-194-22	Motor Protector 220V-60Hz(USA)	1	KA313-GBXL103	(T)	
	053-272-12	Motor Protector 440V-60Hz(USA)	1	KA311-DAXL78	(T)	
20	143-169-17	Truss Screw	2	M3x8	SWRM	
21	115-134-16	Transformer 220V-60Hz(USA)	1	EK200/20		
	115-149-14	Transformer 440V-60Hz(USA)	1	EK400/20		
	115-151-19	Transformer 575V-60Hz(USA)	1	EK525/20		
22	016-139-11	Lead Wire Protection Bush	2	KTVE21.5/22.2		
23	121-445-12	Packing (Water Way, Upp.)	1	KTV2-15/22	NBR	*
24	122-473-12	O-Ring	1	150xd3.3	NBR	*
25	140-427-17	Hex Bolt with Plain Washer	2	M5x15	SUS304	replaces 143-031-22 pan screw
26	090-000-43	Electrode Level Sensor (for USA)	1Set	KTVE	CR	interchangable with OLD part# 090-115-11 (rev1) and 090-000-23 (rev 2) and 090-000-40 (rev3)
	090-124-13	Probe Extension (OPTION)	1		SUS304	OPTIONAL ACCESSORY
27	143-170-11	Truss Screw	2	M4x6	SWRM	
28	127-233-13	Power Relay Fixing Plate	1		SECC	
29	114-170-11	Electromagnetic Contactor	1	G7L-2A-B(DC24V)		
30	121-519-18	Packing (Water Way, Mid.)	1	KTVE21.5/22.2	NBR	*
31	050-431-25	Motor Bracket	1		ADC	
32	122-293-16	O-Ring	1	47xd3.1	NBR	*
33	142-195-19	Wave Washer	1	6204/6303(d47x,0.3t)	SK5	

PARTS LIST		LIGHTWEIGHT AUTOMATIC DEWATERING PUMP				2/13/2018
ITEM	PART No.	DESCRIPTION	QTY	SIZE	MATERIAL	NOTES
34	052-103-18	Bearing	1	6204ZZC3		
35	056-B66-11	Stator 220V-60Hz(USA)	1Set			
		Stator 440V-60Hz(USA)	1Set			
36	145-028-19	Stator Set Pin	1	d6x32	S45C	
37	055-730-19	Rotor	1Set	w/Bearing		
38	147-128-16	Impeller Key	1	5x5x18.5l	SUS403	
39	061-161-12	Bearing Collar	1	d25.1xd36x1.6t	SPC	
40	052-108-13	Bearing	1	6305ZZC3		
41	122-473-12	O-Ring	1	150xd3.3	NBR	*
42	064-000-84	Motor Frame	1		ADC	
43	121-246-11	Packing	1	d10.3xd16x2t	PE	*
44	035-125-13	Oil Plug	1	M10x20(B=13)	SUS304	
45	025-243-17	Mechanical Seal	1	H-20T	SIC	
46	143-070-10	Pan Screw	2	M5x6	SWRM	
47	030-122-15	Seal Stopper	1	H-20	SPC	
48	121-001-04	Packing (Water Way, Low.)	1	KTV2-15/22	SBR	*
49	122-134-18	O-Ring	1	G-115(114.4xd3.1)	NBR	*
50	029-000-77	Oil Casing	1	KTV2-15/22	ADC	interchangeable with OLD part#029-408-14
51	140-270-13	Hex.Socket Cap Bolt	4	M8x30	SUS304	
52	058-000-25	Protection Plate	1	d44xd70x3t	SUS304	interchangeable with OLD part#058-000-10
53	143-166-14	Flat Screw	2	M4x8	SUS304	
54	031-000-08	Wear Ring	1	KTV2-15/22	BR+NR	
55	122-443-13	V-Ring	1	VR-20	NBR	
56	071-297-19	Shaft Sleeve	1	d16xd20x10l	SUS304	
57	021F7317	Impeller (60Hz)	1	KTVE21.5-61	FCD	
58	142-129-12	Plain Washer	1	M12	SUS304	
59	141-007-10	Hex.Nut	1	M12	SUS304	
60	141-032-14	Hex.Cap Nut	1	M12	SUS304	
61	020B1918	Pump Casing	1	KTV2-15/22	BR+NR	
62	127-249-12	Fixing Plate	1	KTV2-15/22	SPCC	
63	023-432-19	Strainer Stand	1	KTV2-15/22	SPCC	
64	140-000-53	Hex.Bolt (w/Plain Washer)	4	M8x85 (22L)	SUS304	
		<b>Oil Lifter Version</b>				
AA	143-070-23	Pan Screw	2	M5x6	SWRM	
BB	030-144-13	Oil Lifter	1	H-20(A)(T)	Resin	
CC	143-070-10	Pan Screw	2	M5x6	SWRM	
DD	030-155-17	Seal Stopper	1	H-20(KTV2)	SPCC	
	173-522-15	<b>Packing O-Ring Set</b>	1Set	(Marked by *)		



MODEL **KTVE21.5-61**

PARTS LIST		LIGHTWEIGHT AUTOMATIC DEWATERING PUMP				2/13/2018
ITEM	PART No.	DESCRIPTION	QTY	SIZE	MATERIAL	NOTES
11	121-001-09	Packing (Hose Coupling)	1	KTV2-15/22	NBR	*
23	121-445-12	Packing (Water Way, Upp.)	1	KTV2-15/22	NBR	*
24	122-473-12	O-Ring (Head Cover/M.Bracket)	1	150xd3.3	NBR	*
30	121-519-18	Packing (Water Way, Mid.)	1	KTVE21.5/22.2	NBR	*
32	122-293-16	O-Ring (Upp. Bearing)	1	47xd3.1	NBR	*
41	122-473-12	O-Ring (M.Bracket/M.Frame)	1	150xd3.3	NBR	*
43	121-246-11	Packing (Oil Plug)	1	d10.3xd16x2t	PE	*
48	121-001-04	Packing (Water Way, Low.)	1	KTV2-15/22	SBR	*
49	122-134-18	O-Ring (M.Frame/O.Casing)	1	G-115(114.4xd3.1)	NBR	*
		Lubricant		Turbine Oil VG32 270ml		

\* Indicates items included in set

PARTS LIST		LIGHTWEIGHT AUTOMATIC DEWATERING PUMP			2/13/2018	
ITEM	PART No.	DESCRIPTION	QTY	SIZE	MATERIAL	NOTES

## EXPLODED VIEW

KTVE21.5-61  
KTVE22.2-61

